

MATRIX (LED) CONSOLE with BVE 19" TV & CAB FOR CABLE/SATELLITE BOX CONTROL

LED





5/2022

BVE Technical Support
Tel: 888.330.4283 x 3 Support@Broadcastvision.com

ACCESS MENU ON CONSOLE TO SET UP FOR CAB CONTROL

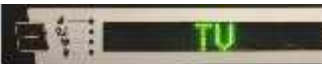
We recommend first setting up the console for CAB control.

1. Use the bottom overlay numeric keypad to enter the console settings.
2. Press Enter 3001 Enter on the numeric keypad.
3. Use the + and – buttons to scroll to TV, press Enter.
4. Use the + and – buttons and scroll to Input Source, press Enter .
5. Use the + and – buttons to scroll to TV, press Enter.
6. Press the Back button to exit back to the welcome screen.
7. Press Enter 0001 Enter. This turns on the entertainment keypad for customer use.



You are now ready to install the CAB

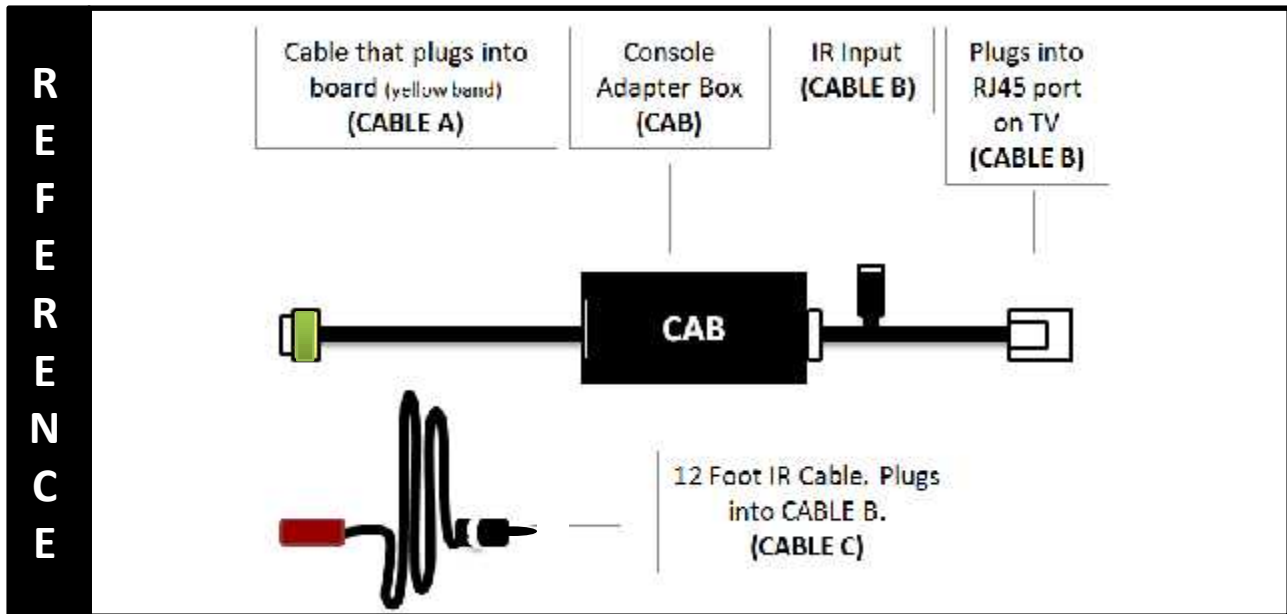

How to Install the CAB

1. Remove the back shroud from the Matrix PLED console.
2. Plug the Green banded side of the CAB (Cable A) into the bottom port of console as shown below.

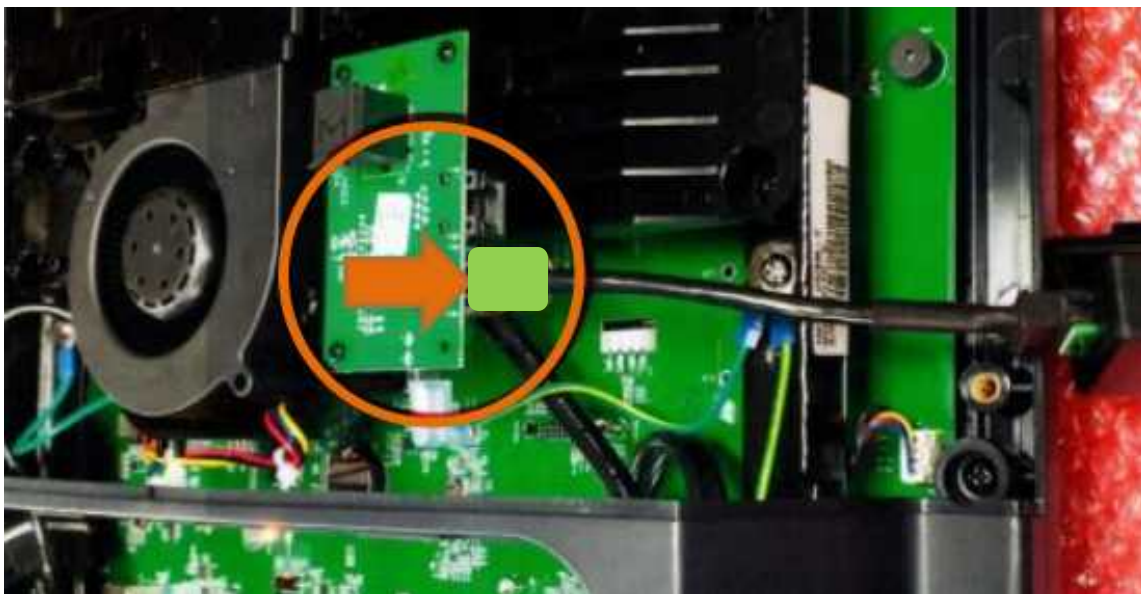

3. Connect (CABLE B) from the other end of the CAB to the RJ45 port on the BVE TV.



4. Connect (CABLE C) into the IR Input on (CABLE B). (CABLE C) is a 12 foot IR cable that is used when the cable or satellite box is next to the cardio equipment. You can also use the adapters that will allow you to extend the IR signal over CAT5.

5. If the cable, satellite or IPTV box (set top box) is located next to the cardio equipment, remove the backing on the IR emitter (CABLE C) and stick onto the set top box (over the IR eye on the STB). Place the IR shield over the IR emitter to help secure the emitter to the STB and to eliminate bleeding of IR signal.

6. Press the channel controls on the console to confirm the channels are changing and to confirm CAB is operating correctly.

Note: If you cannot see where the IR eye is on the front of the STB, shining a flashlight at the front of the box will usually help you to see the IR eye. Please see the IR eye locations of some of the most common STB's below:



Troubleshooting

Double button presses – Some set top boxes respond to more than one of the IR codes that we send out. If you notice that pressing a channel button on the console results in multiple channel changes, simply remove the 2 screws that hold the lid on the CAB and turn on dip switch 2 and 4. If this does not solve the problem, call (888)330-4283 ext.3 for further assistance.

No control over set top box

Check if CAB is getting power and channel commands from the console – CAB contains internal LED power lights. Two indicator LEDs are located on either side of the console-side connector inside the enclosure.

- **GREEN** - Power LED, on whenever the CAB is powered
 - **RED** - Activity LED, flashes whenever the CAB receives and processes commands
- The location of the LEDs is such that they should be visible through the enclosure around the CAB connector to the console.

Incorrect IR emitter placement – If the IR emitter is not in the correct location on the front of the box you may need to move it around until you find the location that works.

Tip: Try initially holding the IR emitter away from the front of the STB initially then continue pressing the channel button while “zeroing in” on the correct IR emitter placement.

Set top box is in RF mode – change to IR mode – Many set top boxes can operate with a hand-held remote in RF or IR mode. For the CAB to function, it is critical that the STB accepts IR channel commands. To test if the STB is in RF mode, place your hand over the hand-held remote control IR transmitter and see if the STB receives channel change commands. If the answer is yes, the STB is in RF mode. Check online for instructions to change the STB remote control mode from RF to IR.

Troubleshooting (continued)

No control over set top box (continued)

IR signal strength issue – In rare circumstances, the CAB may output too strong of an IR signal for the set top box IR receiver. To test if the IR emitter is over-driving the set top box receiver, pull the emitter away from the front of the set top box, and press the channel button to see if the set top box now receives the channel.

No Continuity between CAB and IR emitter – In some circumstances utilizing the “Far” set top box scenario, the CAT5/6 cable between the set top box and the CAB may not provide full continuity through wall plates etc. It may be helpful to re-locate the STB at the base of the cardio and re-test. Or, it may be helpful to temporarily run an alternate CAT5/6 cable from the CAB to the set top box then re-test.

CAB not programmed for the correct set top box - Your CAB is defaulted for Broadcastvision’s popular “Unicode” setting which provides control of the most popular cable, satellite and IPTV set top boxes.

The CAB can be quickly configured on site to operate other popular set top boxes by flipping dip switches inside the CAB enclosure as pictured below. All CABs are shipped pre-programmed what we call unicode. Unicode works with most of the well known providers. If for some reason the CAB is not operational, please call Broadcastvision support at **888.330.4283 x 3** to determine the dip switch settings for your cable, satellite, or IPTV provider.

Note: When the CAB is shipped pre-programmed, the dipswitch setting will be in the OFF position.

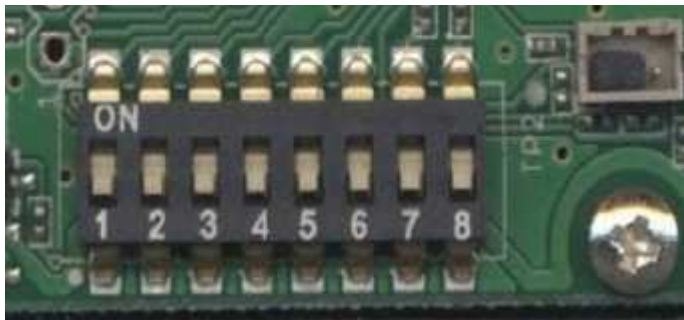

BVE Technical Support

Tel: 888.330.4283 x 3 Support@Broadcastvision.com